

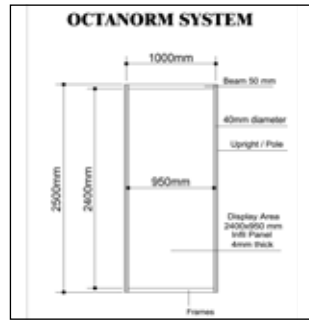

(A) DIGITAL PRINT ON PANEL

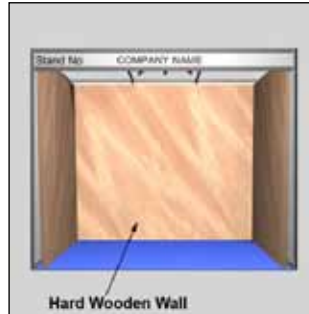

(B) DIGITAL PRINT ON HARD WOODEN WALL



(C) DIGITAL PRINTING ON FOREX

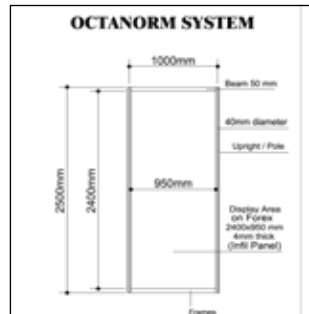

(D) DIGITAL PRINT ON LIGHT BOX (BACKLIT)

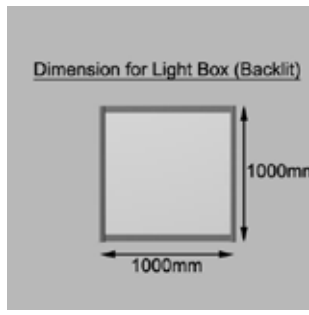

(E) BANNER PRINTING ON PVC WITH WOODEN FRAME  
(1) Wooden Frame on PVC Banner



(E) BANNER PRINTING ON PVC WITH FRAME  
(2) Wooden Frame installation view



EXHIBITIONS & more



MIDDLE EAST  
GEOSPATIAL  
FORUM

# Technical Manual

A DIVISION OF AL FAJER INFORMATION & SERVICES

Deadline: 21 days prior to the start of build-up

Graphic Form

Show Name: \_\_\_\_\_

Company Name: \_\_\_\_\_ Stand No: \_\_\_\_\_ Hall No: \_\_\_\_\_

Telephone # \_\_\_\_\_ Fax # \_\_\_\_\_ E-mail: \_\_\_\_\_

Contact Person: \_\_\_\_\_ Position: \_\_\_\_\_ Date: \_\_\_\_\_

Signature: \_\_\_\_\_ Company Stamp: \_\_\_\_\_

**NOTE:**

- Advertisement charges levied by the Organizers are not included in the below prices.
- The hanging banners will be placed inside the exhibition halls from the ceiling.
- The banners will carry the image, logo and name of the company.
- The cost includes fixing, printing, installating, dismantling and rigging points.

**Materials:**

- All artwork should be in the same size as mentioned.
- Preferred in Adobe Illustrator, Photoshop or in Adobe FreeHand .EPS file format, all text should be in outline. Photoshop EPS should be in 100 dpi in same size as the mention.

Rental rates quoted hereunder are for the entire duration of the Exhibition.

Code	Graphic	Rates in US\$	Rates in Dhs	Quantity	Cost
(A)	<b>DIGITAL PRINT ON PANEL</b> Dimension of Graphic per Panel (W 950 mm x H 2400 mm)	200.00	736.00		
(B)	<b>DIGITAL PRINT ON HARD WOODEN WALL</b> Dimension of Graphics on Wooden Wall per Running meter (W 950 mm x H 2400 mm)	295.00	1083.00		
(C)	<b>DIGITAL PRINTING ON FOREX</b> Dimension of Graphic on Forex (W 950 mm x H 2400 mm)	235.00	862.00		
(D)	<b>DIGITAL PRINT ON LIGHT BOX (BACKLIT)</b> Dimension of Graphic for light box (W 950 mm x H 1000 mm)	200.00	736.00		
(E)	<b>BANNER PRINTING ON PVC WITH FRAME</b> Dimension of Graphic on PVC (W 296 mm x H 2400 mm)	450.00	1656.00		
(F)	<b>DIGITAL PRINTING ON FASCIA</b> Dimension for Fascia Name (W 2930 mm x H 300 mm)	195.00	715.00		
(G)	<b>DIGITAL PRINTING OF LOGO ON FASCIA</b> Dimension for Single Logo (W 963 mm x H 210 mm)	75.00	274.00		
(H)	<b>DIGITAL PRINTING ON LOCKABLE COUNTER</b> Dimension for Digital Printing-Front Area (W 930 mm x H 830 mm) Dimension for Digital Printing-Two Sides (W 430 mm x H 830 mm)	110.00 140.00	405.00 514.00		
(I)	<b>DIGITAL PRINTING ON POP UP</b> Dimension for Pop Up (W 4090 mm x H 2290 mm)	1890.00	6955.00		
(J)	<b>DIGITAL PRINTING ON ROLL UP</b> Dimension for Roll Up (W 850 mm x H 2000 mm)	270.00	994.00		
(K)	<b>DIGITAL PRINTING FOR FREE STANDING</b> Dimension for Free Standing (W 1000 mm x H 2000 mm)	144.00	530.00		
				Total Cost	

Total Amount \_\_\_\_\_

**PAYMENT DETAILS**

Amount in Words \_\_\_\_\_

Orders are valid only when accompanied by full remittance. Payment should be made in favor of AL FAJER INFORMATION & SERVICES in US Dollars Bank Draft or by Telex transfer to our Account.

**HSBC BANK MIDDLE EAST**  
 P.O. Box: 66, Dubai, Main Branch Dubai, U.A.E.  
 Account No. 020-581880-001  
 Swift Code: BBMEAEAD  
 IBAN: AE970200000020581880001

Quotation can be provided separately for items not listed hereunder.

V4/12



(F) DIGITAL PRINTING ON FASCIA

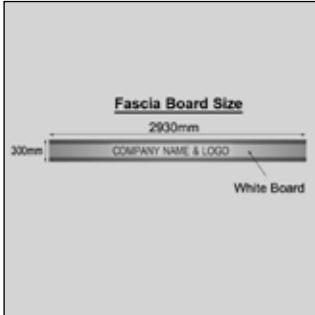

(G) DIGITAL PRINTING OF LOGO ON FASCIA

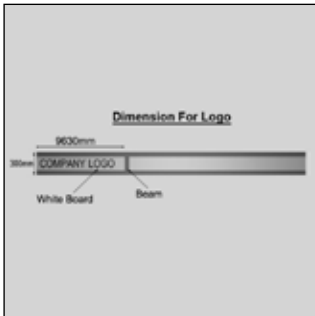

(H) DIGITAL PRINTING ON LOCKABLE COUNTER

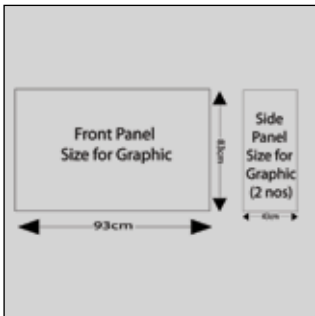

(I) DIGITAL PRINTING ON POP UP

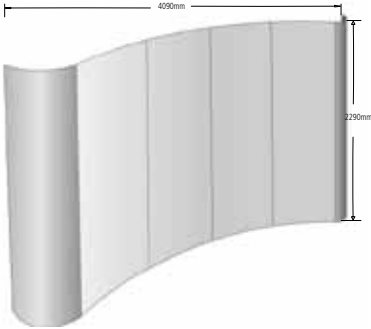

(J) DIGITAL PRINTING ON ROLL UP



(K) DIGITAL PRINTING FOR FREE STANDING

